

Leaf and Debris Vacuum Operating Manual: 18HP Series Truck Loader



IT'S GOT TEETH

	Part No.	Model No.
18hp Skid Mount	MPE-SM18BVG	SM18BVG
18hp Swing Arm	MPE-HMSA18BVG	HMSA18BVG



**Proudly Made in the USA
by an
ISO 9001:2008 Manufacturer**



Read instructions carefully and follow the rules for safe operations. Failure to do so may result in serious injury.



Welcome to Monster Power Equipment Incorporated

Congratulations!

You are now the owner of a state of the art, quality leaf and debris vacuum from Monster Power Equipment, Inc.

Monster Power Equipment manufactures a diversified line of HIGH PERFORMANCE power equipment for leaf and debris solutions, focused on the commercial and municipal lawn care markets.

Team Monster has taken professional landscaping power equipment to a higher standard, offering a robust, uniquely designed, and high performance line of equipment. Monster Power Equipments is designed to meet the challenges of the highly competitive landscape market, providing: flexibility, productivity, and performance, at the same time addressing today's environmental demands.

Table of Content:	Page #:
Introduction _____	2
Safety Rules / Precautions and Graphic Warning _____ (Fed. / CARB and ANSI regulations)	2 - 5
18HP Truck Loader Series Crate Content _____	6
Assembly Instruction _____	7-9
Technical Information – Engine, Fuel and Oil _____	10
Operations – Check Points, Preparation, and Operating Instructions _____	11-13
Transportation _____	14
Replacement Parts _____	15-16
Maintenance and Storage _____	17
Warranty _____	18
Corporate Overview _____	19

Note: Specifications, illustrations and product descriptions in this manual are accurate as of the date printed.

All specifications are subject to change without notice.



Introduction

Monster Power equipment is constructed with heavy gauge metals, and high performance, fuel efficient EPA compliant gas engines, designed for the removal of leaf and debris quickly and efficiently from ground to vehicle. Proper and timely maintenance will assure years of safe, service free, reliable operations.

Please read and understand all safety rules and precautions, and technical, assembly, and operational material before operating your Monster power equipment.

Safety Rules and Precautions



Before starting machine, please carefully read and comply with all safety instructions to reduce the risk of accidents and serious personal injury.

DO NOT EXPOSE YOURSELF AND OTHERS TO DANGER!

- Follow the general safety rules.**
- Do not permit others to run machines unless they are properly trained in its operation.**





All specifications are subject to change without notice.

51 Donnelley Road | Old Saybrook | CT 06475

 860.213.1981  860.388.4488 \ monsterpowerequipment.com

Page | 3

18HP - Op Manual Rev 0 8/8/11

Safety Rules and Precautions

Eye Protection: Always wear safety goggles while operating machine.

Hearing Protection: Always wear hearing protection when operating machine.

Gloves: Always wear protective gloves.

Clothing: Dress properly. Do not wear loose clothing that could become caught in moving parts of the unit (i.e., intake hoses). Long hair should be tied back. Safe, sturdy, non-skid footwear should be worn at all times.



WARNING / DANGER

DO NOT USE the machine if it is damaged or poorly adjusted.

DO NOT remove, guards, shields or safety decals. If a shield, guard or decal is damaged or doesn't function, repair or replace before operating machine.

DO NOT USE any attachment with this leaf and debris machine other than what's offered or recommended by Monster Power Equipment, Inc. because it may cause serious injury to the operator or others in close proximity to machine.

DO NOT USE this machine for any job other than those for which it is intended as described in this manual.

WARNING: KEEP CHILDREN, PETS, AND BYSTANDERS AWAY. Do not permit children to contact machine. Children and on lookers should be kept at a safe distance from work area (100 feet/30meters).

ALWAYS keep a safe distance between two or more operators when working together.

WARNING: When approaching an operator of the machine, be careful not to startle or distract the operator, which may cause an unsafe situation. Carefully call his attention and confirm that the operator **STOPS** the machine prior to approaching them.

NEVER leave machine unattended while operating or engine is running.

BEWARE that the machine is loud and during normal operation it may interfere with verbal communication.

NEVER ALLOW individuals to operate the machine that are not mentally capable.

All specifications are subject to change without notice.



Safety Rules and Precautions, cont.

NEVER ALLOW individuals to operate the machine if they are tired, taking prescription medication, or are under the influence drugs or alcohol.

NEVER ALLOW individuals to ride, sit, or stand on the machine.

NEVER stand in front or behind the machine when operating; the operator **MUST** stay to the side of the machine.

NEVER TRANSPORT the machine while engine is still running.

NEVER TAMPER with governor springs, links, or any other component that may change the governed engine speed.

NEVER look into the hose or discharge chute while machine is running. The discharge chute should always be aimed into a closed, well-ventilated container.

KEEP hands away from hose inlet and discharge chute.

NEVER start or operate machine without suction hose attached properly.

KEEP machine away from FIRE or SPARK.

CAUTION: If tow behind machine is NOT attached to towing vehicle, the stabilizer leg brace must be in the down position and the pin locked in place during start up and operation of machine. The machine **COULD FLIP OVER** if stabilizer leg is not down and locked into position when the engine is brought up to operating speed.

CHECK MOUNTING HARDWARE DAILY!

IMPELLERS



WARNING / DANGER: The engine does **NOT IMMEDIATELY STOP** the impeller from rotating.

NEVER remove the intake cover door from the intake cover assembly.

WARNING / DANGER: If excessive vibration occurs, **TURN OFF** engine, wait for impeller to stop rotating, and disconnect spark plug wires and check for lodged foreign material, damaged impeller, and loose impeller bolt or key.

WARNING / DANGER: **NEVER** try to remove debris from intake or discharge tube when engine is running **OR** impeller is still rotating.

All specifications are subject to change without notice.



General Safety Rules and Precautions, cont.

GRAPHIC WARNINGS

The following stickers are applied to the machine to indicate safety warnings. Do not remove safety stickers and replace any stickers should they become worn.

It is the responsibility of the operator to carefully follow all safety requirements to avoid personal injury or destruction of property.



All specifications are subject to change without notice.

18HP Truck Loader Series Crate Content

Please read and follow all instructions to insure proper assembly.

Skid Mount Power Unit: PN# MPE-SM18BVG

Crate content:

- 1 - Power Unit: Includes Fuel Cell and Battery & Box
- 1 - Discharge Stack Assembly (Stack / Elbow Combination)
- 1 - 7" dia. X 30" Metal Discharge Hose
- 1 - 10' Intake Hose (10" dia.)
- 1 - Intake Nozzle (10" dia.)
- 1 - Intake Nozzle Handle
- 1 - Intake Hose Connector
- 1 - Intake Hose Support Strap (10" dia.)
- 1 - Host Support Boom, with Chain Guide
- 1 - Assembly Kit (Hardware, 2 - 10" Hose Clamps, Support Chain, Metal Discharge Hose Clamp)
- 1 - Battery (Dry without Acid)
- 1 - Operation Manual and Warranty Registration package
- 1 - Engine Operation Manual

Hitch Mount Swing Arm: PN# MPE-HMSA18BVG

Crate Content:

Same as above with the addition of a 49" x 4 x 4" Swing Arm



All specifications are subject to change without notice.

Assembly Instructions

Uncrate Unit & Assemble

STEP 1: Remove Packaging

Remove outer crating and protective packaging. Unfasten the power unit, discharge stack, and hitch mount swing arm from pallet.

STEP 2: Install Hitch Mount Swing Arm to receiver of vehicle. Mount power unit utilizing the supplied 4 - 1/2" X 1" bolts, washers, and nuts.

Note: Lift points on power unit are for installing or removing power unit from hitch mount / swing arm when overhead winch is available.



STEP 3: Stack Assembly

(A) Attach Discharge Stack to blower housing utilizing 8 - (3/8" X 16 X 1 1/4") bolts.



(B) Install 7" dia. Metal Hose to discharge stack using metal hose clamp.

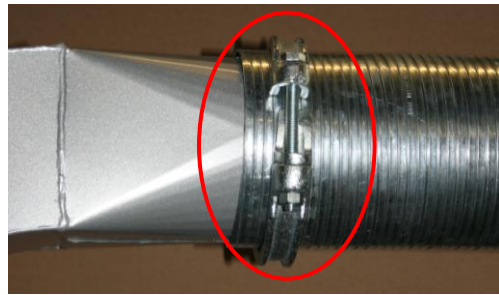

STEP 4: Boom Assembly

(A) Attach Boom Arm to Boom Mast utilizing 2 - (3/8" X 1 1/4") bolts, washer, and nuts.



(B) Install Boom Assembly to receiver on rear of discharge stack.



(C) Attach Boom Chain to Eyelet on End of Boom



All specifications are subject to change without notice.



Assembly Instructions, cont.

STEP 5: Hose Assembly

A: Attach Support Strap to 10" Intake hose utilizing 1-(3/8"X2") bolt w/ flat washer and nylock.



Note: Support Strap Needs to be centered on the Intake Hose.

B: Install Handle to Nozzle assembly.

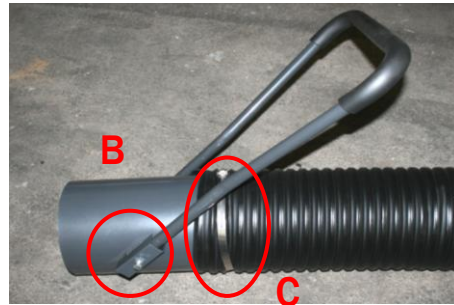

C: Attach Nozzle Assembly to One End of the Intake Hose Utilizing 10" Worm Drive Clamp.

D: Install Intake Hose Connector to Opposite End of Intake Hose Utilizing the Same Size Worm Drive Clamp.

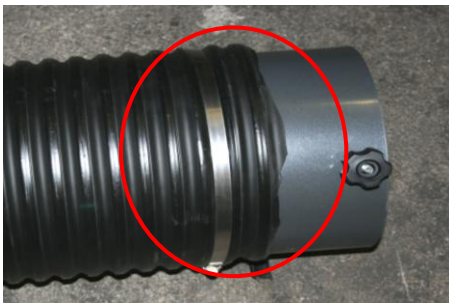

E: Attach Boom Chain to Eyelet on the Support Band.



STEP 5: Install Intake Hose Connector to Intake Cover Assembly.

Note: Never remove the Intake Cover Door from Intake Cover Assembly.



All specifications are subject to change without notice.



Assembly Instructions, cont.

STEP 7: Service and Install Battery - Battery Acid is Not Supplied

Safety Note: EYE PROTECTION and GLOVES are REQUIRED.
Battery Acid Activation should be added in a ventilated area.

A: Install airflow tube to battery and to the drain hole in base of power unit.



B: Install battery to base of power unit and attach battery bracket, utilizing 2- (#12X $\frac{3}{4}$ ") self-tap screws.

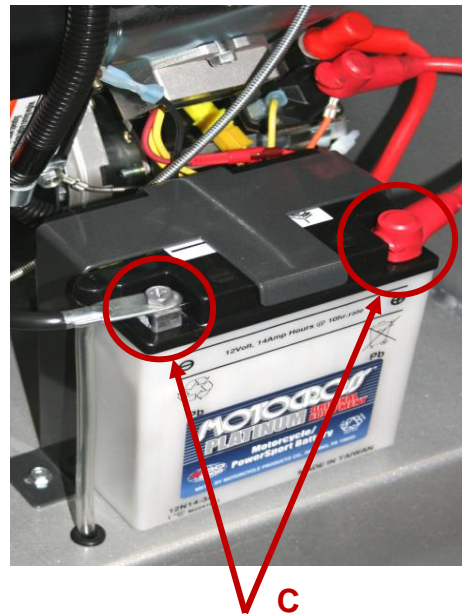

C: Attach Red (positive) and Black (negative) cables to the designated terminals.

STEP 8: Service Engine– See engine manufacture's manual.

Important Note: Don't Stand on Unit.

Warning: Heavy weight. May need assistance installing.



Technical Information

EPA SMALL ENGINES EMISSION REQUIREMENTS

Refer to engine manufacturer manual for specifications and requirements related to the engine. All engines are compliant with EPA and the California Emission regulations (CARB).



WARNING / DANGER: “Proposition 65” engine exhaust contains chemicals known to the state of California to cause cancer, birth defects, or other reproductive harm.

TECHNICAL DATA

Model	SM18BVG	HMSA18BVG	
Engine	18HP Vanguard	18HP Vanguard	
Displacement <small>cm³(cu. In)</small>	479 (29.23)	479 (29.23)	
Starter	Electric / Pull Start	Electric / Pull Start	
Fuel Capacity	1.5 Gal. EPA (Low Perm)	1.5 Gal. EPA (Low Perm)	
Oil Capacity	1.36 – 1.42 Liter	1.36 – 1.42 Liter	
Vacuum Hose	10”dia.x 10’	10”dia.x 10’	
Discharge	7 inch	7 inch	
Class Requirements		Class 3	
Impeller	All Models: 4 Blade 3/8”in. w/ Steel Taper Locking Hub		
Dimensions	Skid Mount:	Shipped - 38”L X 40”W X 32”H Assembled 40” X 37” X 98 Hitch Mount/ Swing Arm:	Shipped - 36”L X 45”W X 80” H Assembled 84” X 55” X 112
Dry Weight	SM: 500 lbs.	HMSA: 620 lbs.	

FUEL



All specifications are subject to change without notice.

Safety Rules & Precautions to Observe: Fuel, Oil, and Engine

DO NOT attempt to re-fuel **HOT** engines. Allow machine to cool down for 2 minutes before removing cap.

DO NOT over fill fuel tank. Fill tank to approximately 1½" below filler neck to allow for fuel expansion.

DO NOT add fuel to tank in a **CLOSED NON-VENTILATED AREA**, or near **SPARKS** or **OPEN FIRE**.

DO NOT re-fuel engine while it is running.

DO NOT smoke while handling fuel or filling tank.

Wipe off spilled fuel before attempting to start engine.

Fuel should always be stored in an approved, clearly marked container.

OIL: ALL MONSTER POWER EQUIPMENT IS SHIPPED WITHOUT OIL!

ENGINE

REFER TO the engine manual for specifications, proper engine preparation, and operation.

ENSURE spark plug, muffler, fuel cap, and air cleaner are properly installed.
Do Not operate engine without muffler or air cleaner.

WIPE OFF spilled fuel before attempting to start engine.

DO NOT crank engine with spark plug removed.

DO NOT choke carburetor to stop engine; instead reduce to idle and turn switch to stop position.

NEVER make engine adjustments while machine is running. Always make adjustments while on a flat and even surface.

NEVER place unit in any areas where there are flammable materials (i.e., dry grass, etc.), combustible gases, or liquids.

NEVER tamper with the engine speed selected by the manufacturer.

NEVER run engines at excessive speeds. This may result in injury and/or damage to the unit.
NOTE: Lead/Acid batteries generate hydrogen/oxygen gases. Keep sparks and flames away at all times.

All specifications are subject to change without notice.



Preparing for Operations

Inspect unit; make sure all guards and deflectors are in place. Check all nuts and bolts to ensure they are installed and properly tightened to appropriate torque specifications.

Repair or replace, as necessary, any missing or damaged components before operating unit. Clean the unit; especially areas such as fuel cell and air cleaner for dirt and debris. Fuel stored longer than 2 months should be drained and replaced.

Reasonable care must be taken when operating equipment. Inspect work area and unit before operating. Make sure all operators of this specific model machine are properly trained and have reviewed all safety rules and precautions.

CHECK POINTS BEFORE OPERATION

Before Starting Engine: Review engine manual when necessary.

To Start Engine:

- Check Oil level (Daily)
- Turn fuel shut off valve to open
- Put choke control in “CHOKE” position
- Move throttle control 1/3 of the way toward high speed position
- Turn key to the START position
- Let engine warm up. Slowly adjust CHOKE toward “RUN” position

To Vacuum: Engine must be running.

- Option 1: Hold the handle of intake nozzle and move in a sweeping motion over debris.
- Option 2: Place intake nozzle on the ground and rake leaves and debris in the direction of the nozzle opening.

To Stop Engine:

- Move the throttle control to the slow position
- Turn key to off position
- Close fuel valve
- Note: Impeller will continue to rotate for several seconds after engine is stopped.



All specifications are subject to change without notice.

Warning / Danger



Never attempt to remove leaves or debris from any part of the equipment while the engine is running or the impeller is rotating!

DEBRIS BLOCKAGE

When experiencing a decrease in suction, there may be a debris blockage in the hose or housing.

Remove Debris Blockage / Hose

- ❑ Grab handle of intake nozzle, stretch hose out into a straight line with respect to the inlet of the vacuum unit while the engine is at FULL throttle.

Remove Debris Blockage / Housing

If after completing the steps above, a decrease in suction still exists, look for blockage in housing.

To inspect housing for blockage complete the following steps:

- ❑ Turn off engine and wait until all moving parts have stopped, including impeller.
- ❑ Disconnect plug wires from spark plugs on engine.
- ❑ Remove hose assembly from the inlet housing.
- ❑ With the hose assembly disconnected from inlet housing, remove any debris from inside of housing.



Caution: Gloves should be worn when clearing debris from inside the housing. Impeller blades are sharp. Housing may also contain other sharp objects, such as glass, aluminum, sticks, etc.

- ❑ Inspect discharge chute for debris and remove any clogs.
- ❑ Re-assemble unit, re-connect spark plug wires and resume operation

RECOMMENDATION FOR OPTIMAL PERFORMANCE

DRY DEBRIS: Run engine at 1/2 throttle.

WET DEBRIS: Run engine at full throttle.



All specifications are subject to change without notice.

SKID MOUNT

- Make sure that engine is turned off.
- Turn fuel valve to the OFF position.
- Remove Intake Hose Assembly.
- Remove Boom Assembly.

HITCH MOUNT SWING ARM

- Make sure that engine is turned off.
- Turn fuel valve to the OFF position.
- Remove Intake Hose Assembly.
- Remove Boom Assembly.
- Check to ensure that the swing arm is in the closed position and the locking bolt is secured and tight.
- Ensure the safety chain is secured to the vehicle.



All specifications are subject to change without notice.

Replacement Parts: SKID Mount Truck Loaders

Item	Part Number	Description	Qty.
1	020035	Blower Housing Assembly	1
2	020036	Discharge Stack	1
3	020037	Intake Cover Assembly	1
4	020038	Door, Intake Cover	1
5	020039	Intake Hose Connector	1
6	020034	Wear Liner KIT	1
7	020040	Nozzle Assembly	1
8	020041	Handle	1
9	020042	Intake Hose Support Strap, 10"	1
10	020043	Boom Mast	1
11	020044	Boom Arm	1
12	020045	Battery Hold-Down	1
13	020028	Impeller Assembly	1
14	020065	Throttle Mounting Bracket	1
15	010014	Metal Hose Clamp (7")	1
16	010007	Worm Drive Clamp	1
17	010015	Shaft Spacer 18HP BVG	1
18	010016	Throttle Cable 18HP BVG	1
19	030024	Metal Hose (7"x30")	1
20	030090	Intake Hose (10"x10')	1
21	090006	Battery (12N14)	1
22	090007	Battery Cable (Red 8")	1
23	090010	Battery Cable (Black 13")	1

Optional Accessories:

Hitch Mount: PN# MPE-020002 (18HP / 14HP - Skid)
 Exhaust Stack Extension 24": PN# MPE- 020116 (18HP)

All specifications are subject to change without notice.



Replacements Parts: Skid Mount Truck Loaders

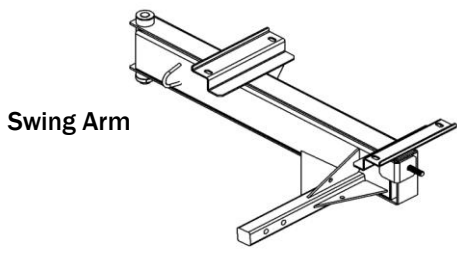
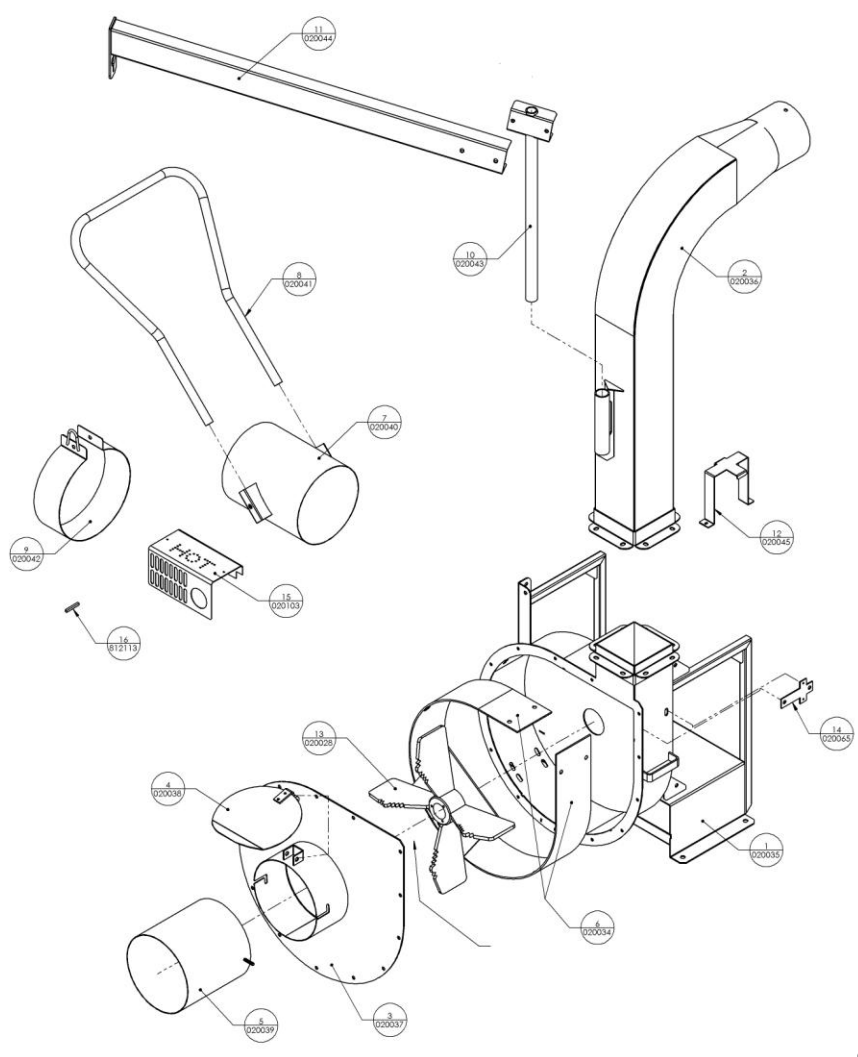

Ordering Information: Contact authorized Monster Power Equipment dealer

All specifications are subject to change without notice.



GENERAL MAINTENANCE

SHUT OFF the engine, ensure fuel valve is in **OFF** position, and all spark plug wires are detached from spark plugs before general maintenance is performed or any type of repairs. It is recommended to disconnect the battery for any major repair.

Always refer to engine manual when it comes to maintenance and repair.

Clear intake screens on housing and engine throughout use.

Keep blower, drives and specifically engine air screen and cooling fins clean and free of grass and leaves to reduce the chance of fire and to permit proper cooling

Check all nuts and bolts are installed and properly tightened to appropriate torque specifications (Especially Impeller bolts). Repair or replace worn, damaged or missing parts immediately

Inspect Impellers regularly. Look for worn, bent or cracked blades. Replace only with factory supplied replacement parts, never try to straighten or weld.

Use only recommended parts, fluid and lubricants specified by engine manufacturer. (Refer to engine manual)

Check Tire air pressure regularly. Specifications are on sidewall of tire

Keep air filters clean and refer to engine manufacturers for cleaning and replacement procedures

Replace all worn or damaged decals

STORAGE

Never store unit indoors or in a poorly ventilated areas unless fuel cell is empty. Fumes may reach open flames, spark or pilot as in furnace or other gas appliances

Disconnect battery when storing unit for any period of time

When unit is in storage for long periods (60 Days or more) fuel should be drained from fuel cell and carburetor, clean parts to prevent gum deposits from forming and causing malfunction of engine. Drain fuel outdoors, into approved fuel container, away from any form of open flame or spark
Run engine until fuel is empty from fuel cell and engine stops

Note: Fuel Stabilizer can be used. Please refer to engine manufacturer manual.



Limited Warranty

The limited warranty set forth below is given by MONSTER POWER EQUIPMENT, INC. ("MPE") with respect to new merchandise purchased and used in the United States or Canada, its possessions and territories (the "Products").

Except as otherwise provided herein, MPE warrants its Products against defects in material and workmanship for a period of 18 months commencing on the date of original purchase and, for Products that shall be rented by the purchaser to third parties, for 90 days. MPE shall, at its option, repair or replace, free of charge, any part found to be defective in material or workmanship during the applicable warranty period. This limited warranty shall only apply if the Product has been operated and maintained in accordance with the operating manual furnished with the Product, and has not been subject to misuse, abuse, neglect, accident, improper maintenance, alteration, vandalism, theft, fire, water or damage because of other peril or natural disaster. Damage resulting from the installation or use of any accessory or attachment not approved by MPE for use with its Products will void this limited warranty as to any resulting damages.

Normal wear parts, consisting of drive belts, hydraulic hoses, tires and batteries, not subjected to misuse, abuse, neglect, accident, improper maintenance, alteration, vandalism, theft, fire, water or damage because of other peril or natural disaster are warranted to be free of defects in material and workmanship for a period of 90 days commencing on the date of original purchase.

HOW TO OBTAIN SERVICE: Warranty service is available, WITH PROOF OF PURCHASE THROUGH AN AUTHORIZED SERVICE PROVIDER. To locate the dealer in your area, please contact MPE at 860 213-1981.

This limited warranty does not provide coverage in the following cases:

- a. The Product's engine or component parts thereof. These items carry a separate manufacturer's warranty. Please refer to the applicable manufacturer's warranty on these items.
- b. Routine maintenance items, other than normal wear parts, such as lubricants, filters, tune-ups and normal deterioration of the exterior finish due to use or exposure.
- c. Service completed by a party other than an authorized distributor/dealer (service provider).
- d. Replacement parts that are not MPE authorized parts.
- e. Transportation and service calls.
- f. MPE does not extend any warranty for Products sold or exported outside of the United States of America and Canada, its possessions and territories, except those sold through MPE's authorized channels of export distribution.

No implied warranty, including any implied warranty of merchantability or fitness for a particular purpose, applies after the applicable period of express written warranty above as to the parts as identified.

No other express warranty or guaranty, whether written or oral, except as mentioned above, given by any person or entity, including a distributor, dealer or retailer, with respect to any Product shall bind MPE. During the period of this Warranty, the exclusive remedy is repair or replacement of the Product as set forth above.

The provisions as set forth in this Warranty provide the sole and exclusive remedy arising from any defect in the material or workmanship of a Product or the components thereof. MPE shall not be liable for incidental or consequential loss or damages including, without limitation, expenses incurred for substitute or replacement equipment, for transportation or for related expenses, or for rental expenses to temporarily replace a warranted Product.

In no event shall recovery under this Warranty of any kind be greater than the amount of the purchase price paid for the Product. Alteration of the safety features of the Product shall void this Warranty. You assume the risk and liability for loss, damage, or injury to you and your property and/or to others and their property arising out of the use or misuse or inability to use the Product.

This limited warranty shall not extend to anyone other than the original purchaser of the Product.

If any provision of this express limited warranty is found to be invalid or unenforceable, then the remainder shall have full force and effect, and the invalid provision shall be partially enforced to the maximum extent permitted by law.

This express limited warranty will be interpreted, construed and enforced in all respects in accordance with the laws of the State of Connecticut, without reference to its choice of law rules.

The Superior Court for the Judicial District of Hartford or the United States District Court for the District of Connecticut will be the sole and exclusive courts of proper jurisdiction and venue of and for any and all legal proceedings relating to this express limited warranty. MPE and the purchaser hereby irrevocably consent to such designation, jurisdiction and venue and waive any objection or defense relating to jurisdiction or venue with respect to any lawsuit or other legal proceeding initiated in or transferred to the Superior Court for the Judicial District of Hartford or the United States District Court for the District of Connecticut.

How State Law Relates to this Warranty: This limited warranty gives you specific legal rights, and you may also have other rights which vary from state to state. In some states limitations on how long an implied warranty lasts or the exclusion or limitation of incidental or consequential damages may not be allowed and therefore inapplicable.

All specifications are subject to change without notice.





About us

Monster Power Equipment Incorporated, (MPE) was established in April of 2011, offering an innovative array of leaf and debris management solutions to the landscape professionals in the commercial and municipal markets.

Monster Power Equipment was established by Sound Manufacturing, Inc, a leading provider of metal fabrication services and contract manufacturing, providing technology, engineering, assembly, logistic capabilities and expertise to commercial and industrial markets. With our expertise in engineering and manufacturing, we are able to bring to you a new, vastly improved series of leaf and debris equipment.

Our Strategy

To provide the end consumer with quality, innovative solutions that increase their efficiency and flexibility, enabling them higher return on investments and profitability.

Our Business Model

To provide the end consumer with quality, innovative solutions that increase their efficiency and flexibility, enabling them higher return on investments and profitability.

Sound Manufacturing, Inc. was established in 1984 and is an ISO 9001: 2008 registered manufacturer.

With 27 years in engineering and fabrication experience, Sound provides the stability and experience to develop and manufacture a product line in the leaf and debris solution industry.

A Perfect FIT.

Monster Power Equipment, Inc. will deliver high quality, value driven equipment designed to increase productivity and profitability.

Power Designed with BITE.

All specifications are subject to change without notice.

